

Wi-Fi® Camera with Night Vision

NETCAM 



User Manual

TABLE OF CONTENTS

Getting Started 1

What's in the Box	1
Initial Setup	1
Set Up Your Camera Wirelessly Through Your Mobile Devices	2

GETTING TO KNOW YOUR Wi-Fi CAMERA 19

Front Panel	19
Back Panel	20

Technical Details 21

Software Features and Specifications	21
Main Window	22
Camera Viewer	23
Protection	24
Web Browser	24

Troubleshooting, Support, and Warranty 28

Belkin International, Inc., Limited 2-Year Product Warranty	30
How to get service.	31
How state law relates to the warranty.....	32
Technical Support	33

Regulatory Information 34

European Compliance Statement:	34
General Safety Information:	34

GETTING STARTED

Congratulations on buying a Belkin NetCam. This device will enable you to easily check in on your home and your loved ones when you are away.

What's in the Box

NetCam

Power Supply

Quick Installation Guide

Mounting Kit

Initial Setup

To get started, you will need:

Your wireless router, its network name (SSID), and password.

An Android™ device (Version 2.2 or later) or an iPhone, iPad, or iPod touch (iOS Version 4.1 or later).

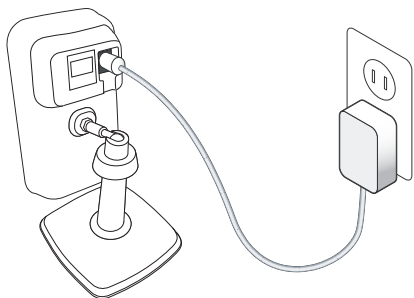

Set Up Your Camera Wirelessly Through Your Mobile Devices

1. Plug the NetCam into a power outlet



2. Switch the NetCam to Setup Mode by flipping up the switch on the back of the camera
Please make sure the switch is in setup mode and the Wi-Fi light is blinking.





3. Download the NetCam App from the App Store or Google Play

4. Set Up on iPhone, iPad, or iPod touch

4.1 Connect your mobile device to NetCam Wi-Fi signal

Go to "Settings > Wi-Fi" on your iPhone/iPad/iPod touch and connect to the camera's Wi-Fi signal.

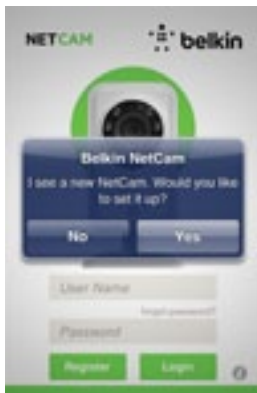

4.2 Launch the NetCam App

Once your device establishes a connection with the camera, launch the NetCam App. You should see a pop-up message like the one below. Click "Yes" to set up your camera.



4.3 Camera Setup

Click "Continue" to begin setup.



4.4 Camera Preview

The camera will show you a preview after successfully connecting to your device.

Click “Connect Camera to Internet.”



4.5 Connect to Internet

Choose your Wi-Fi network to connect to the Internet.

You may also choose to connect to your network via Ethernet cable (not included) by clicking “Ethernet.”



4.6 Connect to Internet

Enter your Wi-Fi password if you have a security-enabled network.



Please wait for the camera to establish connection with the Internet.



4.7 Create an Account

If this is your first time setting up your camera, you will need to create an account.



4.8 Use Existing Account

If you have an existing account, select "Use Existing" and then enter your account information. Click "Sign in."



4.9 Set Up Camera Info

Create the camera name and its description.



Click “Continue.” It will take a few seconds to register the camera with the server.



4.10 Setup Complete

Please flip the setup switch down on the back of the NetCam.

Click "Finish" to complete the setup.



Congratulations!



5. Set Up on Android Devices

5.1 Connect your device to NetCam Wi-Fi signal

Go to “Settings > Wireless” and “Network > Wi-Fi settings” and connect to the camera Wi-Fi signal.



5.2 Launch NetCam App!

Once your device establishes a connection with the camera, launch the NetCam App. You should see a pop-up message like the one below. Click “Yes” to set up your camera.



5.3 Camera Setup

Click "Continue" to begin setup.



5.4 Camera Preview

The camera will show you a preview after successfully connecting to your device. Click "Connect camera to Internet."



5.5 Connect to the Internet

Choose your Wi-Fi network to connect to the Internet.

You may also choose to connect to your network via Ethernet cable (not included) by clicking “Ethernet.”



5.6 Connect to Internet

Enter your Wi-Fi password if you have a security-enabled network.



Please wait for the camera to establish an Internet connection.



5.7 Create an Account

If this is your first time setting up your camera, you will need to create an account.



5.8 Use Existing Accounts

If you have an existing account, select “Use Existing” and then enter your account information. Click “Sign in.”



5.9 Set Up Camera Info

Create the camera name and its description.



Click "Continue." It will take a few seconds to register the camera with the server.



5.10 Setup Complete

Please flip the setup switch down on the back of the NetCam.

Click "Finish" to complete the setup.

Congratulations!



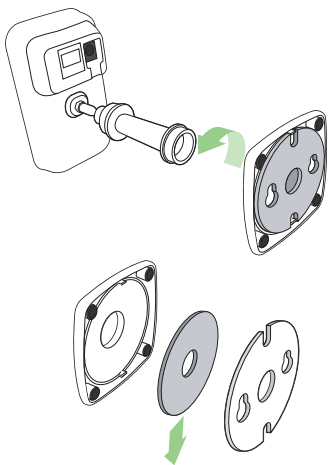

6. Mounting Your Camera (optional)

Unscrew camera post from the base and remove weight.

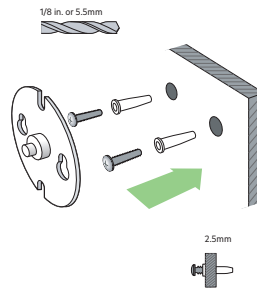

Attach screws to wall and hang plate onto screws.

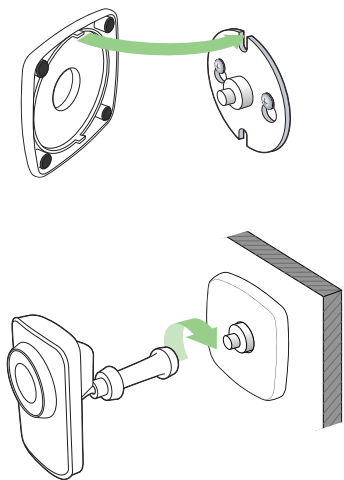

Align base with plate and screw on camera post.

GETTING TO KNOW YOUR WI-FI CAMERA



Front Panel

- A: Brightness sensor
- B: Camera sensor
- C: IR LED
- D: Microphone

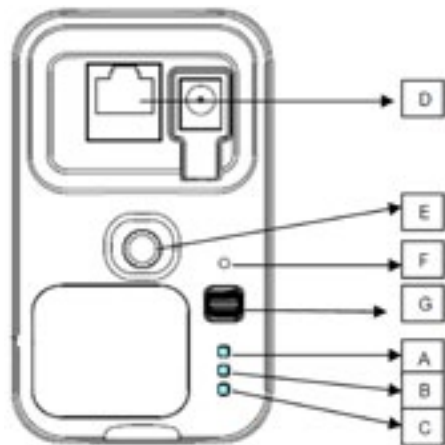

Back Panel

LED Indicators

A: Setup

Green: Setup up mode on
Amber: Setup mode initializing
Light Off: Setup mode off



B: Network

Green: Connected to server
Amber: Connected to local area network only
Flashing Amber: Not connected to any network
Flashing Green: Connected to network, ready to set up



C: Power

Green: Power On



D: RJ45 port:

Can be used for wired setup and for a wired connection with the router while using the NetCam.

E: Camera holder

You can adjust the NetCam's position by adjusting the holder.

F: Reset button

Reset System: Press and hold for 1 second to reset the system.
Factory Default: Press and hold for 20 seconds to restore factory default settings.

G: Setup switch

Flip up to switch to setup mode.
Flip down to switch to camera mode.



Software Features and Specifications

App on iOS or Android

- Camera setup
- Live camera viewing
- Save snapshot and video from the live stream
- Live one-way audio
- Camera settings
 - Enable/disable email alert
 - Camera sharing
 - Set camera status (online, offline, private)
 - Video stream (Frame rate, video resolution, quality)
- General settings
 - Reset password
 - Sign in automatically
- Invite friends to view your camera

Web App

- Live camera viewing
- Live audio on selected PC web browsers (Internet Explorer®, Firefox®, and Google Chrome™)
- Camera settings
- Camera firmware upgrade
- Delete camera
- Invite friends to view your camera
- Enable/disable email alert
- User account management
- Create new user account
- Reset password

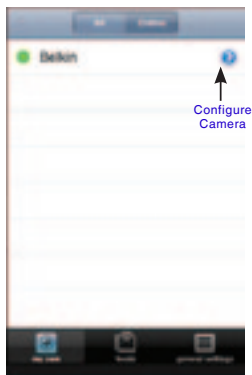

Main Window



Camera Configuration

Name: Name of your camera

Share/unshare: Make your camera public to your friends or not.

Status: Change camera status to be online, offline, or private.

Rotation: Select "Normal" or "Flipped Vertically" on the videos.

IR: Select "Auto," "On," or "Off" of IR LEDs.

Frame Rate: Up to 30fps

Quality: 1-5 (Best = 5)

Video Size: 160x120, 320x240, 640x480.

Microphone > Enable/Disable Microphone

Email alert > Enable/Disable email alert



Take a
Snapshot

Record
Video

Enable Microphone

Camera Viewer

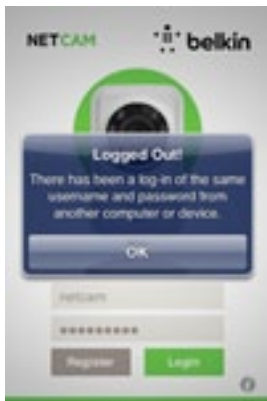

Protection

To protect your security against a hacker, a pop-up message will alert you if someone else is logged into your account at the same time as you.



Web Browser

Access this link via Internet Explorer, Netscape, Firefox, or Google Chrome: <http://www.belkin.com/netcam>

Then you can view the camera via your PC.

Hardware Features and Specifications

Camera	
Image Sensor	VGA 1/4 inch CMOS sensor
Lens	Focal length: 3.1mm, F2.6
View Angle	Horizontal: 64° Vertical: 48° Diagonal: 80°
IR LEDs	8 IR LEDs, 850nm 8-meter illumination distance
IR Mode	Always on Always off Auto mode - IR turns on when luminance decreases to about 3 lux - IR turns off when luminance increases to about 8 lux
Ambient Light Sensor	RoHS-compliant 560nm luminance detector

Video	
Codecs	MJPEG, JPEG for still images
Resolution	160x120, 320x240, 640x480
Frame Rate	Up to 30 frames

Still Image Capture	Support VGA and 0.3MP resolution JPEG still capture
Video Features	Adjust image size and quality Flip and mirror image
Audio	
Audio In	Built-in microphone, -38 dB ± 2 dB
Audio Compression	G.711, PCM

Networking	
Network Interface	10/100Base-TX Fast Ethernet 802.11b/g/n WLAN
Wireless Connectivity	802.11b/g/n Wireless with WEP/WPA/WPA2 security
Radio Specifications	RF band: ISM Band 2.4GHz Channels: Varies by country RF Power Output - 802.11n: 14 ± 1 dBm Average - 802.11g: 14 ± 1 dBm Average - 802.11b: 16 ± 1 dBm Average
Antenna	Type: Chip antenna, SMD Gain: 1.3 dBm peak Efficiency: above 65%

TECHNICAL DETAILS

General	
System	Processor: RT5350 Speed: 360MHz DRAM: 64MB Flash: 8MB
Button	Reset Button - Reset system: Press less than 1 second to reset the system - Factory default: Press and hold 20 seconds to restore the factory default settings
Switch	Setup mode switch: Turn setup mode on and off
LEDs	Setup Mode LED - Solid Green: Setup Mode on - Amber: In progress to switch to Setup Mode - No light: Setup Mode off Network LED - Solid Amber: Local network ok - Solid Green: Connection to Internet ok - Flashing Amber: No network yet - Flashing Green: Global Internet ok System LED - Solid Green: System on

Power	External AC-to-DC switching power adapter Input: 100-249V AC, 50/60Hz, Output: 5V DC, 1A
--------------	--



System Requirements

iPhone, iPad, or iPod touch with iOS 4.1 or above or Android smart devices Version 2.2 or above

PC OS: Windows® XP, Windows Vista®, or Windows 7, or Mac OS® X v10.6.8 Snow Leopard

PC browsers: Internet Explorer 8, Google Chrome 16, Firefox 11.1, Safari® 5.1 Using the latest Adobe Flash Player

Resetting the Camera

The “Reset” button is used in rare cases. In the unlikely event that your camera functions improperly, please use a pin to reset the camera. The Reset button is where the arrow below points. Reset the camera when the switch is in “OFF” mode. After the reset, the camera will resume to the default setting.

- Reset system: Press and hold for 1 second to reset the system
- Reset to factory default: Press and hold for 20 seconds to restore the factory default settings

TROUBLESHOOTING, SUPPORT, AND WARRANTY

If I buy more cameras, could I use the same username to connect them?

Unlimited cameras can be added under your own account, but each one should have a different camera name. The figure below shows that you can have different cameras under your account.

Account Dashboard



How can I share my cameras with my friends?

Log in to your account. Under the camera configuration, find the "Sharing" icon. Type in your friends' email addresses to invite them to see your camera.



How can I upgrade the firmware?

Access your NetCam's account from a web browser. Under the camera configuration, a screen will pop up like the one below. Click "Update Now." It will take about 5-10 minutes to upgrade the new firmware.



Can I change my username?

Your username is what identifies your account information, and once set, it cannot be changed. If you later do not like your username, the only recourse is to create a new account. Please note that any subscription services registered in the old account (if applicable) cannot be transferred to the new account.

Forgot or lost your password?

The NetCam App login screen has a link labeled "Forgot your password?" that takes you to the account sign-in webpage. Type in your username and email address, and then click the Reset button to begin the process of setting up a new password.

Belkin International, Inc., Limited 2-Year Product Warranty

What this warranty covers.

Belkin International, Inc. (“Belkin”) warrants to the original purchaser of this Belkin product that the product shall be free of defects in design, assembly, material, or workmanship.

What the period of coverage is.

Belkin warrants the Belkin product for two years.

What will we do to correct problems?

Product Warranty.

Belkin will repair or replace, at its option, any defective product free of charge (except for shipping charges for the product). Belkin reserves the right to discontinue any of its products without notice, and disclaims any limited warranty to repair or replace any such discontinued products. In the event that Belkin is unable to repair or replace the product (for example, because it has been discontinued), Belkin will offer either a refund or a credit toward the purchase of another product from Belkin.com in an amount equal to the purchase price of the product as evidenced on the original purchase receipt as discounted by its natural use.

What is not covered by this warranty?

All above warranties are null and void if the Belkin product is not provided to Belkin for inspection upon Belkin's request at the sole expense of the purchaser, or if Belkin determines that the Belkin product has been improperly installed, altered in any way, or tampered with. The Belkin Product Warranty does not protect against acts of God such as flood, lightning, earthquake, war, vandalism, theft, normal-use wear and tear, erosion, depletion, obsolescence, abuse, damage due to low voltage disturbances (i.e. brownouts or sags), non-authorized program, or system equipment modification or alteration.

How to get service.

To get service for your Belkin product you must take the following steps:

1. Contact Belkin International, Inc., on the phone number listed on page 32, within 15 days of the Occurrence. Be prepared to provide the following information:
 - a. The part number of the Belkin product.
 - b. Where you purchased the product.
 - c. When you purchased the product.
 - d. Copy of original receipt.

2. Your Belkin Customer Service Representative will then instruct you on how to forward your receipt and Belkin product and how to proceed with your claim.

Belkin reserves the right to review the damaged Belkin product. All costs of shipping the Belkin product to Belkin for inspection shall be borne solely by the purchaser. If Belkin determines, in its sole discretion, that it is impractical to ship the damaged equipment to Belkin, Belkin may designate, in its sole discretion, an equipment repair facility to inspect and estimate the cost to repair such equipment. The cost, if any, of shipping the equipment to and from such repair facility and of such estimate shall be borne solely by the purchaser. Damaged equipment must remain available for inspection until the claim is finalized. Whenever claims are settled, Belkin reserves the right to be subrogated under any existing insurance policies the purchaser may have.

How state law relates to the warranty.

THIS WARRANTY CONTAINS THE SOLE WARRANTY OF BELKIN. THERE ARE NO OTHER WARRANTIES, EXPRESSED OR, EXCEPT AS REQUIRED BY LAW, IMPLIED, INCLUDING THE IMPLIED WARRANTY OR CONDITION OF QUALITY, MERCHANTABILITY OR FITNESS FOR A PARTICULAR PURPOSE, AND SUCH IMPLIED WARRANTIES, IF ANY, ARE LIMITED IN DURATION TO THE TERM OF THIS WARRANTY.

Some states do not allow limitations on how long an implied warranty lasts, so the above limitations may not apply to you.

IN NO EVENT SHALL BELKIN BE LIABLE FOR INCIDENTAL, SPECIAL, DIRECT, INDIRECT, CONSEQUENTIAL OR MULTIPLE DAMAGES SUCH AS, BUT NOT LIMITED TO, LOST BUSINESS OR PROFITS ARISING OUT OF THE SALE OR USE OF ANY BELKIN PRODUCT, EVEN IF ADVISED OF THE POSSIBILITY OF SUCH DAMAGES.

This warranty gives you specific legal rights, and you may also have other rights, which may vary from state to state. Some states do not allow the exclusion or limitation of incidental, consequential, or other damages, so the above limitations may not apply to you.

Technical Support

US

<http://www.belkin.com/support>

UK

<http://www.belkin.com/uk/support>

Australia

<http://www.belkin.com/au/support>

New Zealand

<http://www.belkin.com/au/support>

Singapore

1800 622 1130

Europe

<http://www.belkin.com/uk/support>

You can find technical-support information on our website, www.belkin.com, by navigating to the tech-support section.

If you want to contact technical support by phone, please call the number you need from this list*:

*Local rates apply.

COUNTRY	NUMBER	INTERNET ADDRESS
AUSTRIA	0820 200766	www.belkin.com/de/networking/
BELGIUM	07 07 00 073	www.belkin.com/nl/networking/ www.belkin.com/fr/networking/
CZECH REPUBLIC	239 000 406	www.belkin.com/uk/networking/
DENMARK	701 22 403	www.belkin.com/uk/networking/
FINLAND	0972519123	www.belkin.com/uk/networking/
FRANCE	08 - 25 54 00 26	www.belkin.com/fr/networking/
GERMANY	0180 - 500 57 09	www.belkin.com/de/networking/
GREECE	00800 - 44 14 23 90	www.belkin.com/uk/networking/
HUNGARY	06 - 17 77 49 06	www.belkin.com/uk/networking/
ICELAND	800 8534	www.belkin.com/uk/networking/
IRELAND	0818 55 50 06	www.belkin.com/uk/networking/
ITALY	02 - 69 43 02 51	www.belkin.com/it/networking/
LUXEMBOURG	34 20 80 85 60	www.belkin.com/uk/networking/
NETHERLANDS	0900 - 040 07 90	€0.10 per minute www.belkin.com/nl/networking/
NORWAY	81 50 0287	www.belkin.com/uk/networking/
POLAND	00800 - 441 17 37	www.belkin.com/uk/networking/
PORTUGAL	707 200 676	www.belkin.com/uk/networking/
RUSSIA	8-800-555-0231	www.belkin.com/networking/
SLOVAKIA	08000 04614	www.belkin.com/networking/
SLOVENIA	0800 80510	www.belkin.com/networking/
SOUTH AFRICA	0800 - 99 15 21	www.belkin.com/uk/networking/
SPAIN	902 - 02 43 66	www.belkin.com/es/networking/
SWEDEN	07 - 71 40 04 53	www.belkin.com/uk/networking/
SWITZERLAND	08 - 48 00 02 19	www.belkin.com/de/networking/ www.belkin.com/fr/networking/
UNITED KINGDOM	0845 - 607 77 87	www.belkin.com/uk/networking/
OTHER COUNTRIES	+44 - 1933 35 20 00	

REGULATORY INFORMATION

Europe – EU Declaration of Conformity

This device complies with the essential requirements of the R&TTE Directive 1999/5/EC, the EMC Directive 2004/108/EC, and the low-voltage Directive 2006/95/EC. A copy of the European Union CE marking “Declaration of Conformity” may be obtained at the website: www.belkin.com/doc

General Safety Information:

- For indoor installation only
- For installation with supplied power adapter only
- The supplied power adapter is the product’s switch-off device. The base socket must be near the product and easily accessible.



For information on product disposal please refer to <http://environmental.belkin.com>

