



Wireless Network Access Point

Creata faster wireless network



User Manual

F5D7130

TABLE OF CONTENTS

Introduction	1
Overview	2
Key Features	2
Package Contents	3
System Requirements	3
Specifications	4
Knowing your Wireless Access Point	5
Placement of your Wireless Access Point	7
Installation	8
Setting up your Wireless Computer to Configure the WAP	9
Configuring the WAP Using the Advanced Web-Based User Interface	10
Configuring the Wireless Network Settings	13
WAP Utilities	21
Setting MAC Address Filtering	21
Restarting the WAP	22
Restoring Factory Default Settings	23
Saving a Current Configuration	24
Restoring a Previous Configuration	25
Updating Firmware	27
Changing System Settings	30
Troubleshooting	31
Information	32

INTRODUCTION

Thank you for purchasing the Belkin 54g Wireless Network Access Point (WAP) and welcome to the world of wireless networking. Now you can take advantage of this great new high-speed wireless technology and gain the freedom you need to share files among your home or office computers—without using cables. The WAP acts as a bridge between your existing wired network and your wireless-equipped computers. The easy installation and setup will have you networking wirelessly in minutes. Please be sure to read through this manual completely to be sure that you are getting the most out of your WAP.

OVERVIEW

Key Features

Wide Area Coverage at High Speeds

The Belkin WAP provides coverage over an indoor area up to 300 feet in radius and outdoor area over 1,500 feet in radius.

Up to 128-Bit Encryption

Your Belkin WAP is capable of encrypting (scrambling) the transmitted radio waves so you can be sure that your data is secure. The optional encryption feature allows you to encrypt at 64-bits or 128-bits using a key that you enter yourself.

MAC Address Filtering

For added security, you can set up a list of MAC addresses (unique client identifiers) that are allowed access to your network. Every computer has its own MAC address. Simply enter these MAC addresses into a list using the web-based user interface and you can control access to your network.

Works with Both PCs and Mac® Computers

The WAP supports a variety of networking environments including Mac OS® 8.x, 9.x, X v10.x, AppleTalk®, Linux®, Windows® 95, 98, Me, NT®, 2000, and XP, and others.

Front-Panel Connected LED Display

Lighted LEDs on the front of the WAP indicate which functions are in operation. You'll know at-a-glance whether your WAP is connected to the Internet. This feature eliminates the need for advanced software and status-monitoring procedures.

Vertical or Horizontal Desktop Application

Your WAP can stand vertically on the desktop to save space, or lay down flat on a shelf or under your modem. The included vertical mounting base lets you decide how to position the WAP.

Web-Based Advanced User Interface

You can set up the WAP's advanced functions easily through your web browser, without having to install additional software onto the computer. There are no disks to install or keep track of and, best of all, you can make changes and perform setup functions from any computer on the network quickly and easily.

OVERVIEW

Dynamic Host Configuration Protocol (DHCP) support on-board makes for the easiest possible connection to a network. Once the WAP is physically connected to the network, it will attempt to get an address from a DHCP server upon power up automatically so there is no need for a complicated networking setup.

Applications and Advantages

- Economically connect multiple wireless computers to a network
- SOHO (Small Office/Home Office) networking needs
- Provides the easy and quick small network installation SOHO users need.

Package Contents

- Belkin 54g Wireless Network Access Point
- Vertical Mounting Base (optional use)
- Power Supply
- User Manual

System Requirements

- At least one computer with an installed 54g or 802.11b-compliant wireless Ethernet adapter
- TCP/IP networking protocol installed on each computer
- CAT5 networking cable (or better)
- Microsoft® Internet Explorer 4.0 or later, or Netscape® 4.0 or later

OVERVIEW

Specifications

Standards:	IEEE 802.3 10Base-T Ethernet (WAN) IEEE 802.11b IEEE 802.11g draft (54g)
Wireless:	
Radio Technology	Direct Sequence Spread Spectrum (DSSS)
Data Rate	802.11b: 11, 5.5, 2, 1Mbps 802.11g: 54, 48, 36, 24, 18, 12, 9, 6Mbps
Modulation	802.11b: CCK, DQPSK, DBPSK 802.11g: OFDM
Operating Frequency	2.412-2.497GHz ISM band
Operating Channels	802.11b: 11 for North America, 14 for Japan, 13 for Europe 802.11g: 13 for North America, 13 for Japan, 13 for Europe
Security	64/128-bit WEP
Protocol Supported:	CSMA/CD, TCP, IP, UDP, AppleTalk, and DHCP (client)
Management:	Browser-based
Maximum Users:	32 (WAN)i
Ports:	1 10Base-T RJ45 port, WAN 1 power jack 1 reset button
LEDs:	Power LAN activity WLAN activity

KNOWING YOUR WIRELESS ACCESS POINT

The WAP has been designed to be placed on a desktop vertically or horizontally, or it may be mounted to a wall. The slim design minimizes the desktop space required when placed vertically. All of the cables exit from the rear of the WAP for better organization and utility. The LED indicators are easily visible on the front of the WAP to provide you with information about network activity and status.

Front Panel

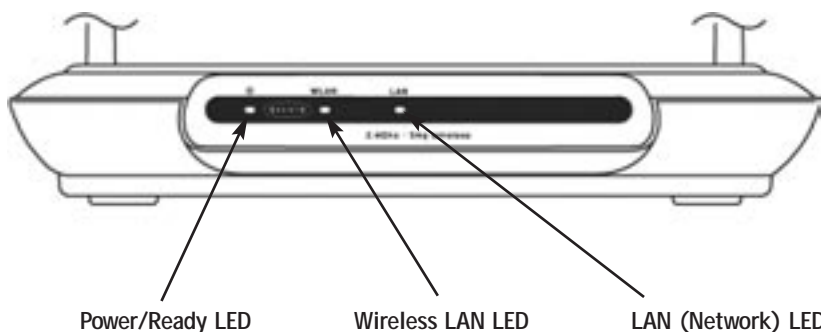

Power/Ready LED	
<i>Indicates that the WAP is receiving power</i>	
OFF	WAP is OFF
Blinking Green	WAP is Booting Up
Solid Green	WAP is Ready

Wireless LAN LED	
OFF	Wireless Network is OFF
Green	Wireless Network is Ready
Blinking Green	Indicates Wireless Activity

LAN (Network) LED	
OFF	No Network is Linked to the Port
Green	10Base-T Connected
Orange	100Base-Tx Connected
Blinking	(Orange or Green) Port Activity

KNOWING YOUR WIRELESS ACCESS POINT

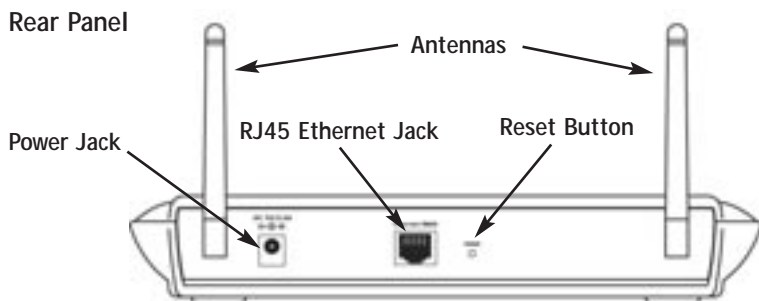

Power Jack

Connect the included 5V DC power supply to this jack.

RJ45 Ethernet Jack

Connect an Ethernet cable to this socket, and connect to an open RJ45 10Base-T or 100Base-T port on a switch, hub, or WAP.

Reset Button

The “Reset” button is used in rare cases when the WAP may function improperly. Resetting the WAP will restore the WAP’s normal operation while maintaining the programmed settings. You can also restore the factory default settings by using the Reset button. Use the restore option in instances where you may have forgotten your custom password.

a. Resetting the WAP

Push and release the Reset button. The lights on the WAP will momentarily flash. The Power/Ready light will begin to blink. When the Power/Ready light becomes solid again, the reset is complete.

b. Restoring the Factory Defaults

Press and hold the Reset button for five seconds then release it. The lights on the WAP will momentarily flash. The Power/Ready light will begin to blink. When the Power/Ready light becomes solid again, the restore is complete.

Rotatable Dual Dipole Antennas

Two unidirectional dipole antennas are located on the side of the WAP. The antennas can rotate 360 degrees. The antennas should be oriented in the vertical position for best performance.

PLACEMENT OF YOUR WIRELESS ACCESS POINT

Proper placement of your WAP is important to ensure the best performance of your wireless network. Typically, indoors your WAP can provide a circular coverage area of 250 feet or more. However, different types of construction materials and other obstructions in a building can greatly affect the wireless signal and decrease the range. Whenever possible, your WAP should be placed as close as possible to the center of the area that you want to cover. In multi-story homes, place the WAP on a floor that is as close to the center of the home as possible; this may mean placing the WAP on an upper floor.

Use care when choosing the location of your WAP

- Be aware of appliances or large objects such as a refrigerator or washer/dryer unit that may be on the opposite side of a wall from where you decide to place your WAP.
- Place the WAP on top of a desk and away from metal cabinets and computer cases.
- Do not place objects or components on top of the WAP.
- Make sure that both antennas are pointing UP at all times.
- Metallic-based UV window tint can affect wireless performance. Do not place the WAP next to a tinted window.

We realize that in the real world, it may not be possible to place your WAP in the center of your coverage area. In cases where you may experience difficulty covering the entire area you want, try placing the WAP as high as possible. Wireless devices work best in a line-of-sight situation where there are no obstacles between the wireless computer and the WAP. The WAP may also be mounted to a wall with the antennas facing UP. There are other options for expanding your wireless coverage area. Visit www.networking.belkin.com for solutions.

The wireless signal can be affected by many things including neighboring wireless networks, microwave ovens in operation, and 2.4GHz cordless phones. While these things can affect the network performance, your wireless network typically will work fine under most conditions where these devices exist.

INSTALLATION

Connecting the WAP to a Cable/DSL WAP, Ethernet Switch, or Hub

Verify the contents of your box. You should have the following:

- Belkin 54g Wireless Network Access Point
- Vertical Mounting Base (optional use)
- Power Supply
- User Manual

1. Select a suitable place for your WAP.
2. Connect a CAT5 cable between the WAP and your cable/DSL WAP's LAN port, Ethernet switch, or hub by plugging one end of the cable into the RJ45 jack on the WAP and the other end into an open RJ45 jack on the cable/DSL WAP, Ethernet switch, or hub.
3. Connect the power supply to the WAP by plugging the round DC connector into the DC jack on the WAP. Plug the power supply into the wall. Verify that the Power LED and the LAN LED are illuminated. If both LEDs are illuminated, this indicates that the WAP is connected properly.
4. Place the WAP on a desktop or mount it to a wall in the location that you have chosen. Next, swivel the antennas so they are both pointing up.
5. Connection and placement of your WAP is now complete. Go to the "Configuring the WAP" section to learn how to configure the WAP.

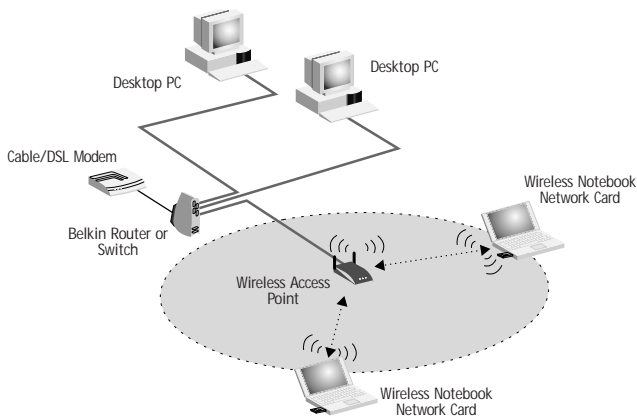

SETTING UP YOUR WIRELESS COMPUTER TO CONFIGURE THE WAP

You will need to set your Wireless Client to the same subnet as the WAP before you can access the Web-based interface. Perform the following steps from the computer you wish to configure your WAP from:

NOTE: You must undo these steps once you have complete configuring your WAP.

Windows 98, ME, 2000 and XP

1. Go to the Windows control panel and double-click on the Network icon or the Network Connections icon.
2. Right-click on the Local Area Connection for your Wireless adapter and select Properties.
3. In the General Tab select the Internet Protocol TCP/IP settings for your wireless adapter and click on the Properties button.
4. Select the "Use the following IP address" radio button.
5. Enter an IP address in the same subnet as the Access Point. For Example: 192.168.2.200
6. Enter the following subnet mask: 255.255.255.0 then click OK

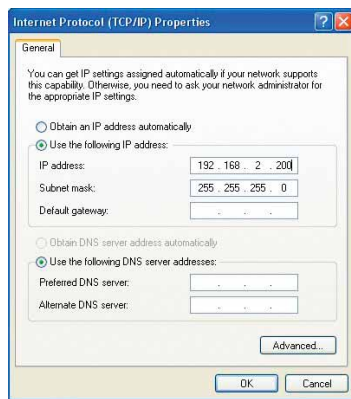

Note: Once you have completed configuring your WAP, repeat steps 1 through 3 above. Then select "Obtain an IP automatically" or set a valid IP for your computer on the same subnet as the network you are connecting to.

CONFIGURING THE WAP USING THE ADVANCED WEB-BASED USER INTERFACE

Using your Internet browser, you can access the WAP's web-based advanced user interface. In your browser, type "192.168.2.254" (do not type in anything else such as "http://" or "www"). Then press the "Enter" key.

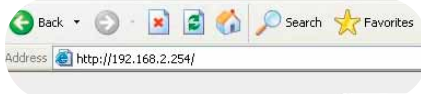

Logging into the WAP

You will see the WAP's home page in your browser window. The home page is visible to any user who wants to see it. To make any changes to the WAP's settings, you have to log in. Clicking the "Login" button or clicking on any one of the links on the home page will take you to the login screen. The WAP ships with no password entered. In the login screen, leave the password blank and click the "Submit" button to log in.



Logging out of the WAP

One computer at a time can log in to the WAP for the purposes of making changes to the settings of the WAP. Once a user has logged in to make changes, there are two ways that the computer can be logged out. Clicking the "Logout" button will log the computer out. The second method is automatic. The login will time out after a specified period of time. The default login time out is 10 minutes. This can be changed from one to 99 minutes. For more information, see the section in this manual titled "Changing System Settings".

CONFIGURING THE WAP USING THE ADVANCED WEB-BASED USER INTERFACE

Understanding the Advanced Web-Based User Interface

The home page is the first page you will see when you access the advanced web-based user interface (UI). The home page shows you a quick view of the WAP's status and settings. All advanced setup pages can be reached from this page.

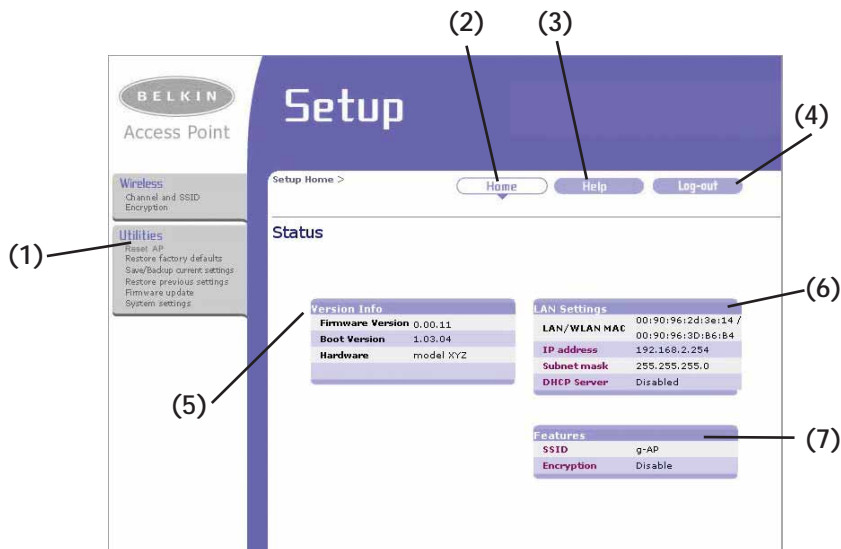

(1) Quick Navigation Links

You can go directly to any of the WAP's advanced UI pages by clicking directly on these links. The links are divided into logical categories and grouped by tabs to make finding a particular setting easier to find.

(2) Home Button

The home button is available in every page of the UI. Pressing this button will take you back to the home page.

(3) Help Button

The "Help" button gives you access to the WAP's help pages. Help is also available on many pages by clicking "more info" next to certain sections of each page.

CONFIGURING THE WAP USING THE ADVANCED WEB-BASED USER INTERFACE

(4) Login/Logout Button

This button enables you to log in and out of the WAP with the press of one button. When you are logged into the WAP, this button will change to read "Logout". Logging into the WAP will take you to a separate login page where you will need to enter a password. When you are logged in to the WAP, you can make changes to the settings. When you are finished making changes, you can log out of the WAP by clicking the "Logout" button. For more information about logging into the WAP, see the section called "Logging into the WAP".

(5) Version Info

Shows the firmware version, boot-code version, hardware version, and serial number of the WAP.

(6) LAN Settings

Shows you the settings of the Local Area Network (LAN) side of the WAP.

(7) Features

Shows the status of the WAP's wireless setting. Changes can be made to the settings by clicking on any one of the links or by clicking the Quick Navigation links on the left side of the screen.

CONFIGURING THE WIRELESS NETWORK SETTINGS

The Wireless tab lets you make changes to the wireless network settings. From this tab you can make changes to the wireless network name (SSID), operating channel, and encryption security settings.

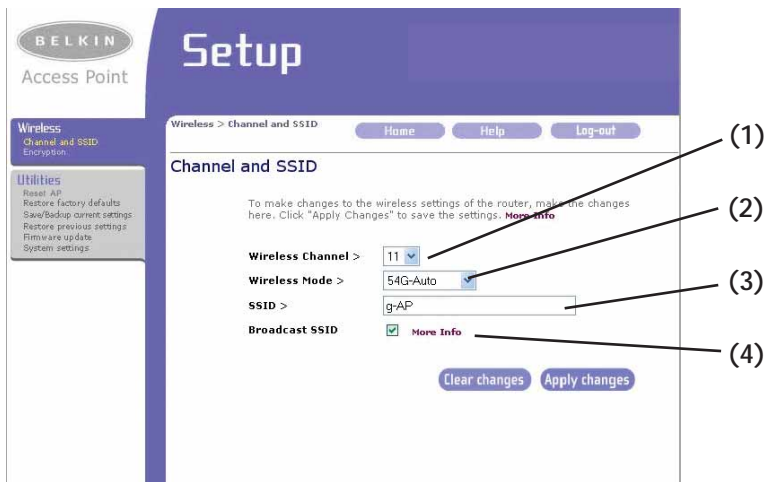

(1) Wireless Channel

Shows you the current channel your WAP is using. You may select one of 11 channels.

(2) Wireless Mode

Shows the current mode of wireless operation. You may select one of three modes.

(3) SSID

Shows the current name of the WAP.

(4) Broadcast SSID

Shows whether SSID is enabled or disabled.

CONFIGURING THE WIRELESS NETWORK SETTINGS

Changing the Wireless Channel

There are a number of operating channels you can choose from. In the United States, there are 11 channels. In the United Kingdom and most of Europe, there are 13 channels. In a small number of other countries, there are other channel requirements. Your WAP is configured to operate on the proper channels for the country you reside in. The default channel is 11. The channel can be changed if needed. If there are other wireless networks operating in your area, your network should be set to operate on a channel that is different than the other wireless networks. For best performance, use a channel that is at least five channels away from the other wireless network. For instance, if another network is operating on channel 11, then set your network to channel 6 or below. To change the channel, select the channel from the drop-down list. Click "Apply Changes". The change is immediate.

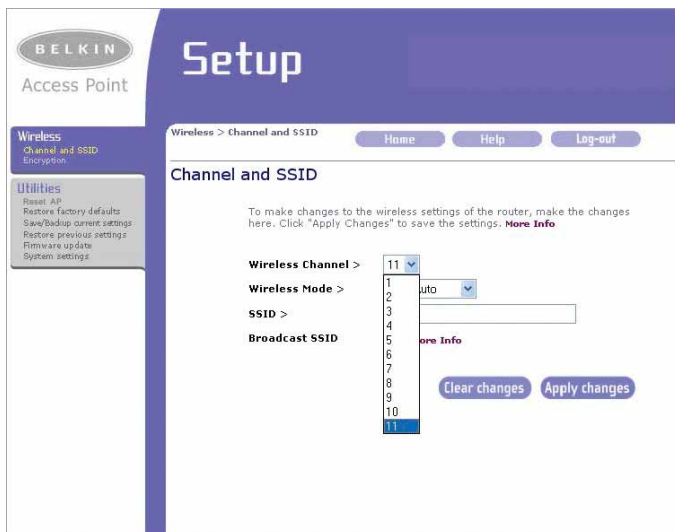

CONFIGURING THE WIRELESS NETWORK SETTINGS

Using the Wireless Mode Switch

Your WAP can operate in three different wireless modes: “54g-Auto”, “54g-Only”, and “802.11b-Only”. In 54g-Auto mode, the WAP will be compatible with 802.11b and 54g wireless clients simultaneously. This mode is the factory default and ensures full compatibility with all Wi-Fi-compatible devices. Set the WAP to 54g-Auto mode if you have a mix of 802.11b and 54g clients in your network. 54g-Only mode will be compatible with 54g clients only. This mode can be useful only if you do not have any 802.11b clients that need access to the network. 802.11b-Only mode will be compatible with 802.11b clients only. This mode can be useful if you have 802.11b clients only that need access to the network. To switch modes, select the desired mode from the drop-down box next to “Wireless Mode” then click “Apply Changes”.

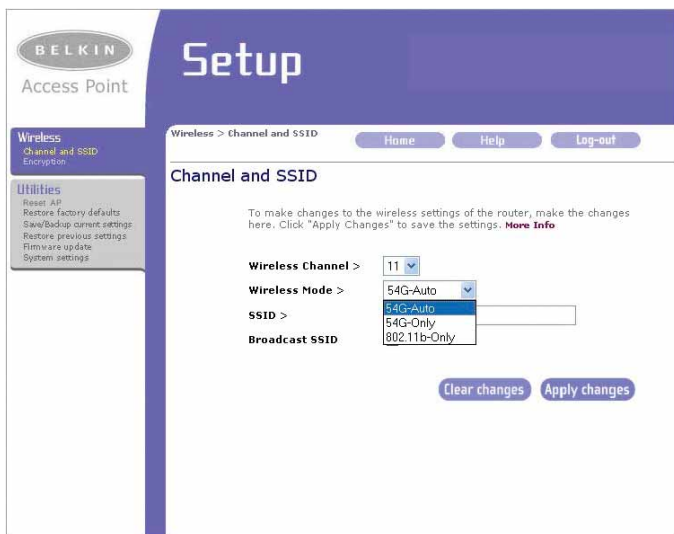

CONFIGURING THE WIRELESS NETWORK SETTINGS

Changing the Wireless Network Name (SSID)

To identify your wireless network, a name called the SSID (Service Set Identifier) is used. The default SSID of the WAP is “WLAN”. You can change this to anything you want to or you can leave it unchanged. If there are other wireless networks operating in your area, you will want to make sure that your SSID is unique (does not match that of another wireless network in the area). To change the SSID, type in the SSID that you want to use and click “Apply Changes”. The change is immediate. If you make a change to the SSID, your wireless-equipped computers may also need to be reconfigured to connect to your new network name. Refer to the documentation of your wireless network adapter for information on making this change.



Using the Broadcast SSID Feature

NOTE: This advanced feature should be employed by advanced users only. For security, you can choose not to broadcast your network's SSID. Doing so will keep your network name hidden from computers that are scanning for the presence of wireless networks. To turn off the broadcast of the SSID, remove the check mark from the box next to "Broadcast SSID", and then click "Apply Changes". The change is immediate. Each computer now needs to be set to connect to your specific SSID; an SSID of "ANY" will no longer be accepted. Refer to the documentation of your wireless network adapter for information on making this change.

CONFIGURING THE WIRELESS NETWORK SETTINGS

Changing the Wireless Encryption Settings

Clicking on the “Encryption” link in the “Wireless” tab will take you to the encryption settings screen. To make setting up your network for the first time easy, the WAP ships with encryption turned off. If you wish to turn on encryption, you can do so from this page. Turning on encryption will require you to set each of your wireless-equipped computers with the same encryption settings that you make in the WAP. Refer to the documentation of your wireless network adapter for information on making this change.

There are two types of encryption to choose from: 64-bit and 128-bit encryption. Using encryption will make your network more secure, but will slow down the network performance. Although network performance will be reduced, it is likely the change will not be detectable to users of the network.

Setting Encryption Automatically Using a Passphrase

Note to Mac users: The Passphrase option will not operate with Apple® AirPort®. To configure encryption for your Mac computer, set the encryption using the manual method described in the next section.

1. Select “64-bit automatically” or “128-bit automatically” from the drop-down menu.



CONFIGURING THE WIRELESS NETWORK SETTINGS

2. Type in a passphrase. A passphrase is like a password. It can be a mixture of numbers and letters. After you type in your passphrase, click "Generate". When you click "Generate", the key fields below will become populated.

NOTE: 64-bit encryption will generate four keys and 128-bit encryption will generate only one key. Select the key you want to use by clicking the radio button next to it. Click "Apply Changes".

3. Encryption in the WAP is now set. Each of your computers on your wireless network will now need to be configured with the same passphrase. Refer to the documentation of your wireless network adapter for information on making this change.

CONFIGURING THE WIRELESS NETWORK SETTINGS

2. If using 64-bit encryption, there will be four key fields. If using 128-bit encryption, there will be one key field. In the key field(s), type in the hexadecimal key(s) that you wish to use. When finished typing in your keys, select which key you want to use by clicking the radio button next to it. Click "Apply Changes".
3. Encryption in the WAP is now set. Each of your computers on your wireless network will now need to be configured with the same hexadecimal key. Refer to the documentation of your wireless network adapter for information on making this change.

Setting MAC Address Filtering

NOTE: This feature may not exist in your current WAP firmware. Please check belkin.com for the latest firmware updates that will support his feature.

The MAC address filter is a powerful security feature that allows you to specify which computers are allowed on the network. Any computer attempting to access the network that is not specified in the filter list will be denied access. When you enable this feature, you must enter the MAC address of each client (computer) on your network to allow network access to each. The “Block” feature lets you turn on and off access to the network easily for any computer without having to add and remove the computer’s MAC address from the list.

MAC address filtering

This feature lets you set up a list of allowed clients. When you enable this feature, you must enter the MAC address of each client on your network to allow network access to each.
[More Info](#)

Enable MAC Address Filtering >

MAC Address Filtering List >

Block	Host	MAC Address	
<input type="checkbox"/>		<input style="width: 80%;" type="text"/>	<input type="button" value=" << Add"/>

To enable this feature, select “Enable MAC Address Filtering” (1). Next, enter the MAC address of each computer on your network by clicking in the space provided (2) and entering the MAC address of the computer you want to add to the list. Click “Add” (3), then “Apply Changes” to save the settings. To delete a MAC address from the list, simply click “Delete” next to the MAC address you wish to delete. Click “Apply Changes” to save the settings.

NOTE: You will not be able to delete the MAC address of the computer you are using to access the WAP’s administrative functions (the computer you are using now).

Restarting the WAP

Sometimes it may be necessary to restart or reboot the WAP if it begins working improperly. Restarting or rebooting the WAP will NOT delete any of your configuration settings.

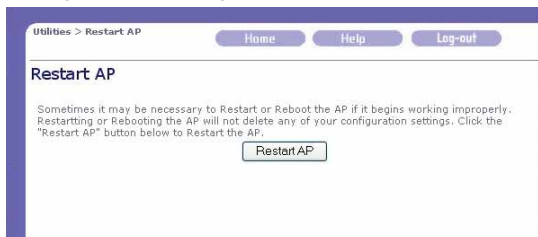

Restarting the WAP to Restore Normal Operation

1. Click the "Restart WAP" button.

2. The following message will appear. Click "OK".

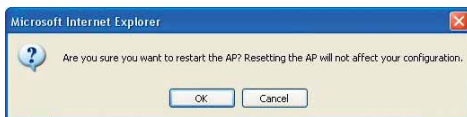

3. The following message will appear. Restarting the WAP can take up to 60 seconds. It is important not to turn off the power to the WAP during the restart.



4. A 60-second countdown will appear on the screen. When the countdown reaches zero, the WAP will be restarted. The WAP home page should appear automatically. If not, type in the WAP's address (default = 192.168.2.254) into the navigation bar of your browser.



Restoring Factory Default Setting

Restoring Factory Default Settings



1. Click the "Restore Defaults" button.

2. The following message will appear. Click "OK".



3. The following message will appear. Restoring the defaults includes restarting the WAP. It can take up to 60 seconds. It is important not to turn the power to the WAP off during the restart.

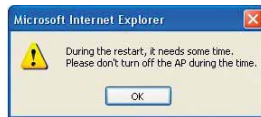

4. A 60-second countdown will appear on the screen. When the countdown reaches zero, the WAP's defaults will be restored. The WAP home page should appear automatically. If it does not, type the WAP's address (default = 192.168.2.254) into the navigation bar of your browser.



Saving a Current Configuration

You can save your current configuration by using this feature. Saving your configuration will allow you to restore it later if your settings are lost or changed. It is recommended that you back up your current configuration before performing a firmware update.

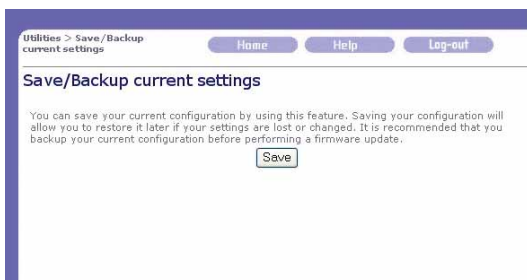

1. Click "Save". A window called "File Download" will open. Click "Save".



2. A window will open that allows you to select the location where you want to save the configuration file. Select a location. You can name the file anything you want, or use the default name "Config". Be sure to name the file so you can locate it yourself later. When you have selected the location and name of the file, click "Save".

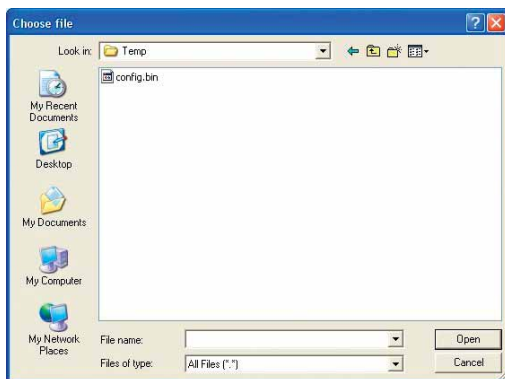

- When the save is complete, you will see the window below. Click "Close".

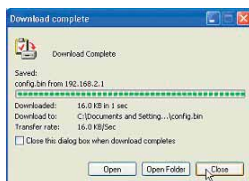

The configuration is now saved.

Restoring a Previous Configuration

This option will allow you to restore a previously saved configuration.



- Click "Browse". A window will open that allows you to select the location of the configuration file. All configuration files end with a ".bin". Locate the configuration file you want to restore and double-click on it.

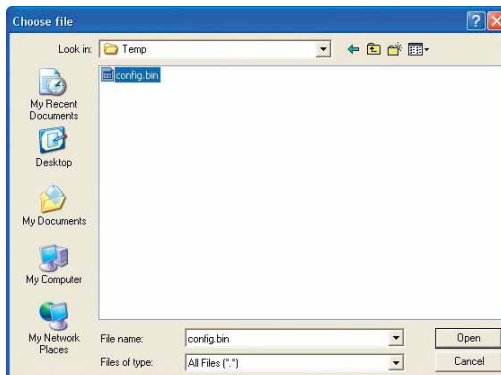

- You will be asked if you want to continue. Click "OK".

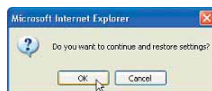

WAP UTILITIES

3. A reminder window will appear. It will take up to 60 seconds for the configuration restoration to complete. Click "OK".



4. A 60-second countdown will appear on the screen. When the countdown reaches zero, the WAP's configuration will be restored. The WAP home page should appear automatically. If not, type in the WAP's address (default = 192.168.2.254) into the navigation bar of your browser.

Restored Settings Successfully

The restored settings is complete when the power light stops blinking.

Router is rebooting seconds remaining.

Updating Firmware

From time to time, Belkin may release new versions of the WAP's firmware. Firmware updates contain feature improvements and fixes to problems that may have existed. When Belkin releases new firmware, you can download the firmware from the Belkin website and update your WAP's firmware to the latest version.

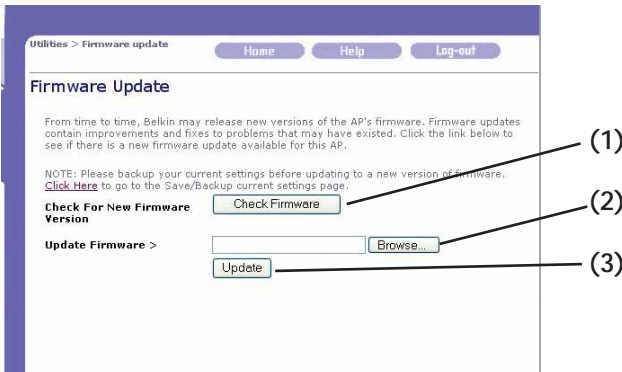

Checking for a New Version of Firmware

The "Check Firmware" (1) button allows you to instantly check for a new version of firmware. When you click the button, a new browser window will appear informing you that either no new firmware is available or that there is a new version available. If a new version is available, you will have the option to download it.

Downloading a New Version of Firmware

If you click the Check Firmware button and a new version of firmware is available, you will see a screen such as the following.

1. To download the new version of firmware, click "Download".

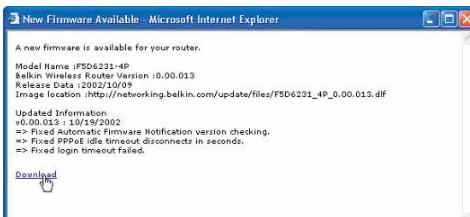

WAP UTILITIES

2. A window will open that allows you to select the location where you want to save the firmware file. Select a location. You can name the file anything you want, or use the default name. Be sure to save the file in a place where you can locate it yourself later. When you have selected the location, click "Save".



3. When the save is complete, you will see the following window. Click "Close".

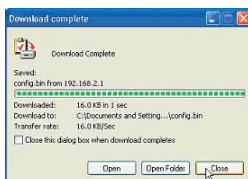

The download of the firmware is complete. To update the firmware, follow the next steps in "Updating the WAP's Firmware".

Updating the WAP's Firmware

1. In the "Firmware Update" page, click "Browse". A window will open that allows you to select the location of the firmware update file. All firmware files end with a ".dlf".

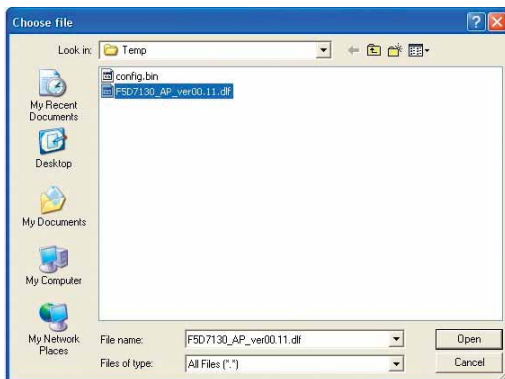

2. Browse to the firmware file you downloaded. Select the file by double-clicking on the file name.

3. The "Update Firmware" box will now display the location and name of the firmware file you just selected. Click "Update".



4. You will be asked if you are sure you want to continue. Click "OK".



5. You will see one more message. This message tells you that the WAP may not respond for as long as one minute as the firmware is loaded into the WAP and the WAP is rebooted. Click "OK".

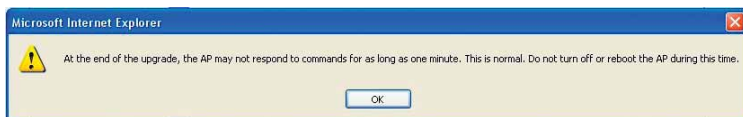

- A 60-second countdown will appear on the screen. When the countdown reaches zero, the WAP firmware update will be complete. The WAP home page should appear automatically. If not, type in the WAP's address (default = 192.168.2.254) into the navigation bar of your browser.



The firmware update is complete.

Changing System Settings

The "System Settings" page is where you can enter a new administrator password and set the login timeout of the WAP.

Setting or Changing the Administrator Password

The WAP ships with NO password entered. If you wish to add a password for greater security, you can set a password here. Write down your password and keep it in a safe place, as you will need it if you log into the WAP in the future.

The screenshot shows a web interface with a purple header. The breadcrumb is "Utilities > System settings". There are three buttons: "Home", "Help", and "Log-out". The main heading is "System Settings". Under "Administrator Password:", there is a note: "The AP ships with NO password entered. If you wish to add a password for more security, you can set a password here. [More Info](#)". Below this are four rows of input fields: "Type in current Password >", "Type in new Password >", "confirm new Password >", and "Login Timeout >". The "Login Timeout" field has the value "10" and "(1-99 minutes)". At the bottom are two buttons: "Clear changes" and "Apply changes".

TROUBLESHOOTING

You can find technical support information at www.networking.belkin.com or www.belkin.com through the tech support area. If you want to contact technical support by phone, please call 800-223-5546. Technical support is available 24-hours-a-day, 7-days-a-week.

INFORMATION

FCC Statement

DECLARATION OF CONFORMITY WITH FCC RULES FOR ELECTROMAGNETIC COMPATIBILITY

We, Belkin Corporation, of 501 West Walnut Street, Compton, CA 90220, declare under our sole responsibility that the product,

F5D7130

to which this declaration relates, complies with Part 15 of the FCC Rules. Operation is subject to the following two conditions: (1) this device may not cause harmful interference, and (2) this device must accept any interference received, including interference that may cause undesired operation.

Caution: Exposure to Radio Frequency Radiation.

The radiated output power of this device is far below the FCC radio frequency exposure limits. Nevertheless, the device shall be used in such manner that the potential for human contact normal operation is minimized.

When connecting an external antenna to the device, the antenna shall be placed in such a manner to minimize the potential for human contact during normal operation. In order to avoid the possibility of exceeding the FCC radio frequency exposure limits, human proximity to the antenna shall not be less than 20cm (8 inches) during normal operation.

Federal Communications Commission Notice

This equipment has been tested and found to comply with the limits for a Class B digital device, pursuant to Part 15 of the FCC Rules. These limits are designed to provide reasonable protection against harmful interference in a residential installation.

This equipment generates, uses, and can radiate radio frequency energy. If not installed and used in accordance with the instructions, it may cause harmful interference to radio or television reception, which can be determined by turning the equipment off and on, the user is encouraged to try and correct the interference by one or more of the following measures:

- Reorient or relocate the receiving antenna.
- Increase the distance between the equipment and the receiver.
- Connect the equipment to an outlet on a circuit different from that to which the receiver is connected.
- Consult the dealer or an experienced radio/TV technician for help.

Modifications

The FCC requires the user to be notified that any changes or modifications to this device that are not expressly approved by Belkin Components may void the users authority to operate the equipment.

Canada- Industry Canada (IC)

The wireless radio of this device complies with RSS 139 & RSS 210 Industry Canada. This Class B digital complies with Canadian ICES-003.

Cet appareil numérique de la classe B conforme à la norme NMB-003 du Canada.

Europe-European Union Notice

Radio products with the CE 0628 or CE alert marking comply with the R&TTE Directive (1995/5/EC) issued by the Commission of the European Community.

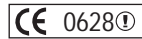

Compliance with this directive implies conformity to the following European Norms (in brackets are the equivalent international standards).

- EN 60950 (IEC60950) – Product Safety
- EN 300 328 Technical requirement for radio equipment
- ETS 300 826 General EMC requirements for radio equipment.



To determine the type of transmitter, check the identification label on your Belkin product.

Products with the CE marking comply with the EMC Directive (89/336/EEC) and the Low Voltage Directive (72/23/EEC) issued by the Commission of the European Community. Compliance with these directives implies

conformity to the following European Norms (in brackets are the equivalent international standards).

- EN 55022 (CISPR 22) – Electromagnetic Interference
- EN 55024 (IEC61000-4-2,3,4,5,6,8,11)- Electromagnetic Immunity
- EN 61000-3-2 (IEC610000-3-2) - Power Line Harmonics
- EN 61000-3-3 (IEC610000) – Power Line Flicker
- EN 60950 (IEC60950) – Product Safety



Products that contain the radio transmitter are labeled with CE 0628 or CE alert marking and may also carry the CE logo.



belkin.com

Belkin Corporation

501 West Walnut Street
Compton • CA • 90220 • USA
Tel: 310.898.1100
Fax: 310.898.1111

Belkin Components, Ltd.

Express Business Park
Shipton Way • Rushden • NN10 6GL
United Kingdom
Tel: +44 (0) 1933 35 2000
Fax: +44 (0) 1933 31 2000

Belkin Components B.V.

Starparc Building • Boeing Avenue 333
1119 PH Schiphol-Rijk • The Netherlands
Tel: +31 (0) 20 654 7300
Fax: +31 (0) 20 654 7349

Belkin, Ltd.

7 Bowen Crescent • West Gosford
NSW 2250 • Australia
Tel: +61 (0) 2 4372 8600
Fax: +61 (0) 2 4372 8603

Belkin Tech Support

US: 310.898.1100 ext. 2263
800.223.5546 ext. 2263
Europe: 00 800 223 55 460
Australia: 1800 666 040

P74218