

Clear Picture

PURE|AV™  
by Belkin

Clean Sound

Home Cinema Power Protection with PureFilter™ Technology  
Power Console PF40

# User Manual



# Table of Contents

	Page
<b>Introduction</b> .....	2
<b>Safety Precautions</b> .....	3
<b>Package Contents</b> .....	4
<b>Power Console Features</b> .....	5
<b>Hookup and Installation</b>	
<b>Step 1</b> Mounting your Power Console (Optional).....	7
<b>Step 2</b> Remote AC Operation .....	8
<b>Step 3</b> Remote DC Operation .....	9
<b>Step 4</b> Connect Digital Components to the Digital Filter .....	10
<b>Step 5</b> Connect Video Components to the Video Filter .....	11
<b>Step 6</b> Connect Audio Components to the Audio Filter .....	12
<b>Step 7</b> Connect High-Current Audio Filter (8-Second Delay) .....	13
<b>Step 8</b> Connect your Pay-Per-View/Phone Line .....	14
<b>Step 9</b> Connect your Cable TV/Satellite Coaxial Lines .....	15
<b>Step 10</b> Connect your Broadband Ethernet Line .....	16
<b>Operation</b> .....	17
<b>Technical Specifications</b> .....	19
<b>Troubleshooting</b> .....	20
<b>Glossary of Power Terms</b> .....	22
<b>Belkin Connected Equipment Warranty</b> .....	23

# Introduction

Thank you for purchasing the PureAV Power Console. The Power Console is designed to clean, protect, and efficiently distribute power to your valuable home cinema system. The PureAV Power Console ensures that every movie you watch and every album you hear is as clean and clear as possible.

The Power Console is packed with innovative features to provide you with the best home cinema experience. Ordinary household AC power that is delivered to your home is polluted with “noise” from many sources inside your home, including computers, general electronics, and kitchen/household appliances. The Power Console’s advanced PureFilter Circuitry™ is optimised to remove electrical noise and provide clean and clear power to all of your valuable digital, audio, video, and high-current equipment. The multiphase PureFilter Circuitry provides true isolation between audio, video, digital, and high-current components. This isolation prevents noise created by components that are already connected to the Power Console from contaminating other connected equipment. In addition, the Power Console contains Advanced Overvoltage Protection, which automatically disconnects power from your equipment when the input voltage reaches a dangerous level, and restores power automatically when the voltage returns to a safe level.

We also realise that the aesthetics of your system are very important. For this reason, we enlisted some of the top industrial designers in the world to design the housing for the PureAV Power Console. The minimalist styling of the Power Console combines function with a simple-yet-elegant design and is a great complement to any home cinema system. The integrated multifunction Liquid Crystal Display (LCD) combines all essential controls with a versatile voltage and current monitor.

As you may know, your AC power source is not the only threat to the safety of your equipment. This is why the PureAV Power Console has three sets of coaxial connections to protect your cable TV, antenna, and satellite signal lines. The Power Console also includes telephone ports to protect Pay-Per-View lines and broadband Ethernet ports to protect data lines that stream digital content to your home cinema system.

Providing the ultimate home cinema experience is the driving force behind the PureAV design, providing the clearest picture and cleanest sound from your components to you. Thank you again for purchasing the PureAV Power Console.

**Clear Picture - Clean Sound. PureAV.**

# Safety Precautions

## **Warning - Earthing**

This product must be plugged directly into an earthed AC power socket. Do not plug or "daisy-chain" this product into other electrical products such as surge protectors, power strips, or UPSes. Do not plug this product into an extension cable. Failure to plug this product directly into an earthed socket may result in personal injury or damage to your equipment, and void your Belkin Connected Equipment Warranty. Call a licensed electrician if you are unsure if your AC sockets are properly earthed.

## **Warning - Rooftop Antennas and Satellite Dishes**

If you use rooftop antennas, satellite dishes, or any other rooftop hardware that connects to your PureAV Power Console, make sure that all the wires leading from these components are properly earthed. This will protect against voltage surges from lightning strikes or static charges.

## **Warning - Lightning Storm Protection**

Although your PureAV Power Console is built to withstand large power surges, we cannot guarantee that it will protect all of your equipment in the event of a large lightning storm. In the event of a lightning storm, it is best to unplug your Power Console from the wall. Once you have done this, there is no need to unplug any of the equipment that is connected to the Power Console.

## **Warning - Water and other Liquids: Shock Hazard**

Do not use this product with aquariums or other water-related products. Use indoors and in dry locations only. Do not operate the Power Console if any liquid is spilled on or in the unit. Failure to follow these guidelines could result in serious bodily injury or death.

## **Warning - Cleaning**

**Always unplug the Power Console from the AC wall socket before cleaning!** It is only necessary to clean the Power Console with a clean, dry cloth or duster. Do not use any cleaning solutions, sprays, or immerse in water. On occasion, it may be necessary to clean the front fascia in order to remove fingerprints. Simply dampen a soft cloth with warm, soapy water and rub gently. Dry the front fascia immediately and thoroughly before applying power to the Power Console.

**Note:** Do not use an excessive amount of water to clean the front fascia.

## **Warning - No User-Serviceable Parts Inside**

If for any reason your Power Console is malfunctioning, do not attempt to repair or dismantle the unit in any way. Unplug the unit and consult this User Manual for warranty and service contact information.

# Safety Precautions

## Warning - Power Cable Safety

Do not route the Power Console's AC power cable near heat sources. This could damage the power cable and cause it to malfunction, creating a shock hazard.

Do not route the Power Console's AC power cable in heavy foot-traffic areas where it could create a trip hazard (hallways, doorways, across room).

If the power cable is frayed, ripped, cut, or damaged in any way, please discontinue use immediately and refer to the warranty section of this User Manual for instructions.

## Waste Handling (or Recycling) - Power Console

The use of the symbol indicates that this product may not be treated as household waste. By ensuring this product is disposed of correctly, you will help prevent potential negative consequences for the environment and human health, which could otherwise be caused by inappropriate waste handling of this product. For more detailed information about recycling of this product, please visit our website at [www.belkin.com](http://www.belkin.com) (or contact your local city office, your household waste disposal service, or the shop where you purchased the product)



# Package Contents

- User Manual
- PureAV Power Console PF40
- One Pair of Rack-Mount Brackets
- Remote AC Control Cable
- Remote DC Control Cable (3.5mm jack cable)
- 1.8m (6 ft.) RJ45 Ethernet Patch Cable - For broadband connectivity
- 1.8m (6 ft.) BT Phone Cable
- 1.8m (6 ft.) PureAV F-Type Coaxial Signal Cables for Satellite/Cable TV
- 1.8m (6 ft.) PureAV Coaxial Aerial Cable
- One Sheet of PureAV Cable Labels

# Power Console Features

1. **Switched Button** - turns on and off the power to the Power Console's "switched" sockets
2. **Auxiliary Socket** - offers optimal connection for digital components, ideal for temporary connection of equipment such as video/digital cameras, game consoles, or any device you wish to power
3. **Central LCD Control** - controls and monitors the Power Console's vital functions
4. **Digital Filter** - ensures optimum reduction of line noise and interference to your digital components (dual-stage digital filter)
5. **Video Filter** - ensures optimum reduction of line noise and interference to your video components (single-stage analog filter)
6. **Audio Filter** - ensures optimum reduction of line noise and interference to your audio components (single-stage analog filter)
7. **HiCurrent™ Filter** - delivers high current to power-hungry amplifiers and receivers; optimised to filter-out AC line noise to these components

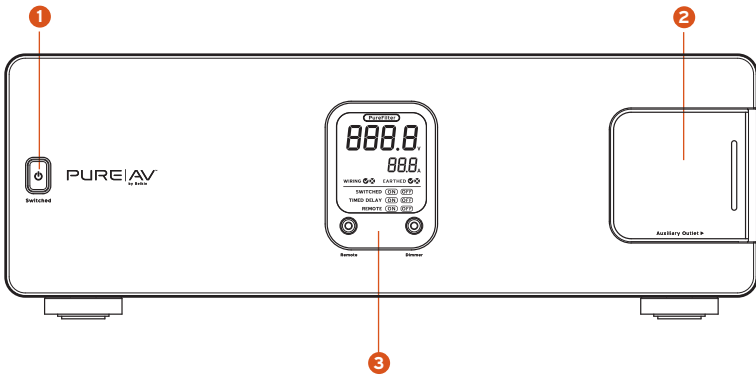

# Power Console Features

- 8. Remote AC/DC Trigger** - allows for remote turn on/off of switched sockets on the Power Console (equipped with both AC and DC inputs)
- 9. Cable TV, Antenna, and Satellite-Line Input/Output** - protects coaxial-cable lines from dangerous electrical disturbances that can travel down your coaxial-cable lines
- 10. Pay-Per-View/Phone-Line Input/Output** - protects Pay-Per-View, phone, or DSL lines from dangerous power surges that can damage your equipment; built-in splitter turns one line into 2
- 11. Broadband Ethernet Input/Output** - protects broadband Ethernet lines used for digital media receivers, gaming, or broadband Internet access from dangerous power surges
- 12. 10-Amp Circuit Breaker** - offers safety of resettable circuit breaker
- 13. Earth Screw** - provides an earthing point for unearthed components

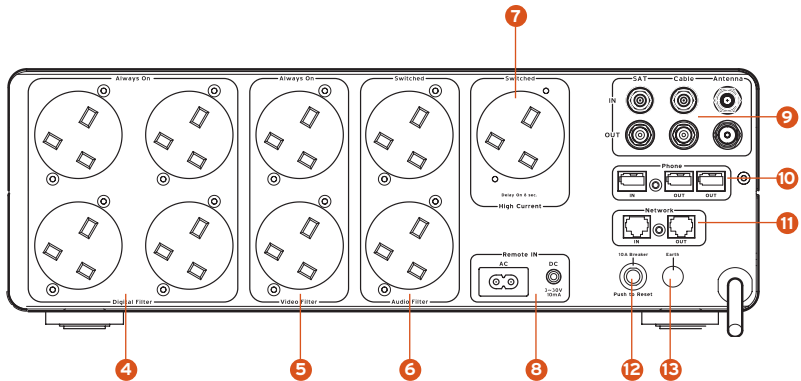

# Hookup and Installation

## Step 1

### Mounting your Power Console (Optional)

The PureAV Power Console can be mounted to a standard AV equipment rack or inside a cabinet equipped with an equipment rack.

- A. Remove the mounting from the box.
- B. Make sure that the Power Console is unplugged.
- C. Align the bracket with the front of the Power Console for flush installation in the rack.
- D. Attach the bracket to the side of the Power Console (Fig. 1). You must use a minimum of four screws to mount each bracket.
- E. Repeat steps C and D for installation of the bracket to the other side of the Power Console.
- F. Mount the Power Console to the equipment rack.

**Note:** Screws for mounting the Power Console to the equipment rack are not provided as they are made specifically for the particular equipment rack that you own. Contact the manufacturer of the rack if you do not have the correct mounting screws.

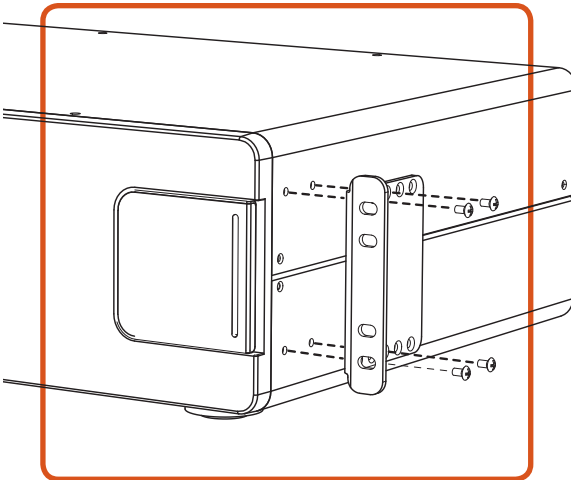

Fig. 1



# Hookup and Installation

## Step 2

### Remote AC Operation

This function allows you to turn your Power Console on and off via your preamplifier or receiver equipped with a switched European power socket.

**Note:** You cannot turn off the switched sockets on the Power Console with the "Switched" button on the front of the unit when there is any external power signal supplied to either the AC or DC remote inputs.

To install the Remote AC Control Cable:

- A. Plug the C8 (Fig. 8 - female) end of the included Remote AC Control Cable into the "Remote AC IN" socket located on the back of the Power Console. (Fig. 2a)
- B. Press the "Remote" button on the front of the Power Console to turn on the remote function. The LCD display should read "REMOTE ON". (Fig. 2b)
- C. Press the "Switched" button on the front of the Power Console to turn off the switched sockets.
- D. Connect the Europlug (male) end of the Remote AC Control Cable into a switched power socket on a preamplifier or receiver. When you turn on the receiver or preamplifier, the sockets on the Power Console that are programmed as "Switched" will be turned on immediately and the "Switched/Delayed" sockets will come on after an eight-second delay.

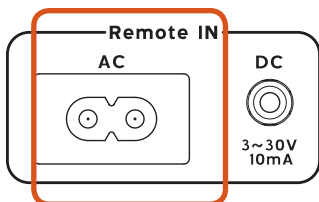

Fig. 2a

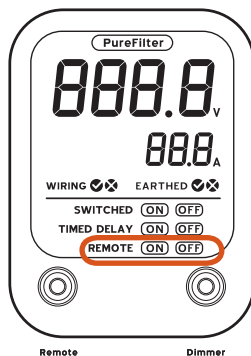

Fig. 2b

# Hookup and Installation

## Step 3 Remote DC Operation

This function allows you to turn your Power Console on and off via any component that is equipped with a 3~30V DC output (low-voltage trigger out).

**Note:** You cannot turn off the switched sockets on the Power Console with the “Switched” button on the front of the unit when there is any external power signal supplied to either the AC or DC remote inputs.

To install the Remote DC Control Cable:

- A. Connect the Remote DC Control Cable (included) into the socket labeled “DC IN” on the rear panel of the Power Console. (Fig. 3a)
- B. Press the “Remote” button on the front of the Power Console to turn on the remote function. The LCD display should read “REMOTE ON”. (Fig. 3b)
- C. Press the “Switched” button on the front of the Power Console to turn off the switched sockets.
- D. Connect the other end of the Remote DC Control Cable into the 3~30V output (low-voltage trigger out) on your component. When you turn on the component, the sockets on the Power Console that are programmed as “Switched” will be turned on immediately and the “Switched/Delayed” sockets will come on after an eight-second delay.

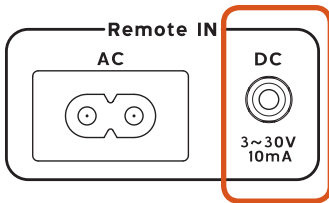

Fig. 3a

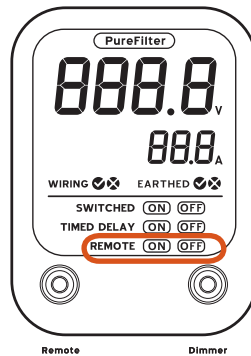

Fig. 3b

# Hookup and Installation

## Step 4

### Connect Digital Components to the Digital Filter

The PureAV Power Console PF40 has one digital filter. The isolated digital filter is optimised to clean and condition the power to all of your digital components. The digital filter also filters out noise created by digital components, such as DVD players, and isolates your digital components from connected video, audio, and high-current audio components.

- A. Attach PureAV power cable labels to each component's power cable before you plug the cable into the sockets on the Power Console.
- B. Connect the power cables of your digital components to any socket labeled under the "Digital Filter". Examples of the most common digital components are listed below:
  1. Digital Cable/Satellite Signal Box
  2. HDTV/Digital Display
  3. Digital Video Recorder (DVR) or Personal Video Recorder (PVR) (for example, TiVo®)
  4. DVD Player
  5. CD Player
  6. Digital Audio Tape (DAT) Player

**Note:** You can connect any type of digital component into any of the digital filter sockets. You are not limited to the components listed above.

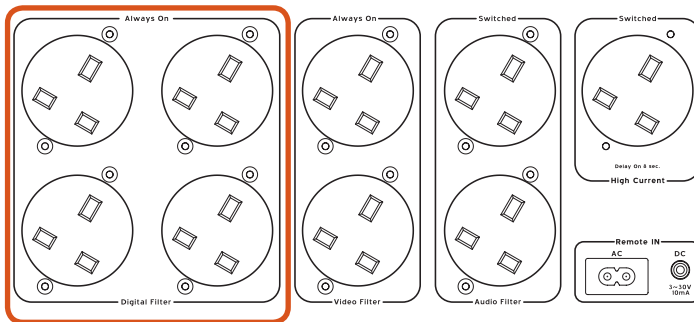

# Hookup and Installation

## Step 5

### Connect Video Components to the Video Filter

The PureAV Power Console contains an isolated video filter that is optimised to clean and condition the power to all of your video components. The video filter also isolates your video components from connected digital, audio, and high-current audio components.

- A. Attach PureAV power cable labels to each component's power cable before you plug the cable into the sockets on the Power Console.
- B. Connect the power cables of your video components to any socket labeled under the "Video Filter". Examples of the most common video components are listed below:

1. TV/Monitor
2. VCR
3. Analog Cable TV Set-Top Box
4. Projector

**Note:** You can connect any type of video component into any of the video filter sockets. You are not limited to the components listed above.

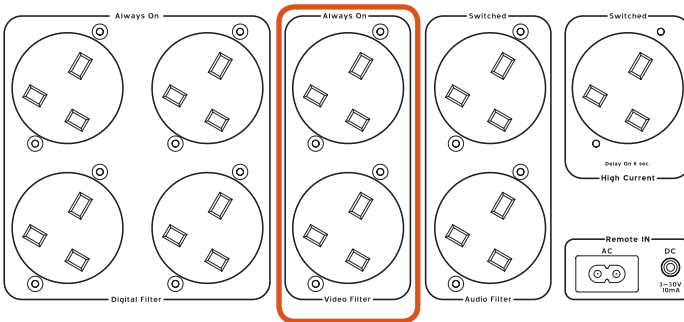

# Hookup and Installation

## Step 6

### Connect Audio Components to the Audio Filter

The PureAV Power Console contains an isolated audio filter that is optimised to clean and condition the power to all of your audio components. The audio filter also isolates your audio components from connected digital, video, and high-current audio components.

- A. Attach PureAV power cable labels to each component's power cable before you plug the cable into the sockets on the Power Console.
- B. Connect the power cables of your audio components to any socket labeled under the "Audio Filter". Examples of the most common audio components are listed below:

1. Tape Player
2. Receiver (Preamp)
3. Turntables

**Note:** You can connect any type of audio component into any of the the audio filter sockets. You are not limited to the components listed above.

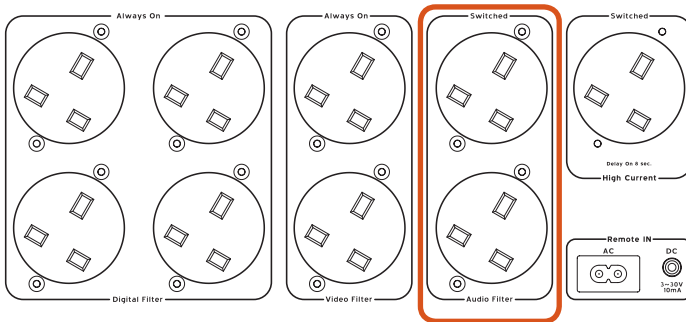

# Hookup and Installation

## Step 7

### Connect High-Current Audio Filter (8-Second Delay)

The HiCurrent™ socket is specifically designed to filter out AC line noise while delivering maximum current to power-hungry amplifiers and other high-current audio components.

**Note:** The HiCurrent socket is equipped with an eight-second delay. This allows your high-current amplifiers to turn on last and turn off first, avoiding that annoying and potentially damaging “thump” from getting to your speakers.

**A.** Attach PureAV power cable labels to each component’s power cable before you plug the cable into the HiCurrent socket on the Power Console.

**B.** Connect your high-current device into the “HiCurrent Filter”.  
Examples of the most common high-current components are listed below:

1. Amplifiers
2. Powered Sub-Woofers
3. Electrostatic Speakers

**Note:** You can connect any type of high-current audio component into any of the high-current sockets. You are not limited to the components listed above.

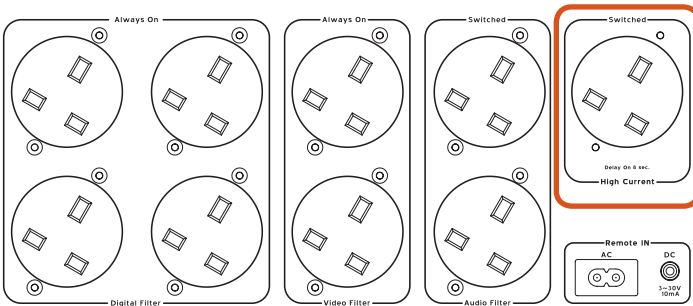

# Hookup and Installation

## Step 8

### Connect your Pay-Per-View/Phone Line

Your PureAV Power Console comes equipped with Pay-Per-View/phone-line protection with a built-in splitter. These are standard BT RJ11 phone ports and are labeled "Phone".

- A. Connect one end of your telephone cable to the wall port to which you normally connect your phone line. Connect the other end of your telephone cable to the Power Console phone port labeled "IN".
- B. Connect one end of the PureAV phone cable (included) to the Power Console phone port labeled "OUT". Connect the other end of this cable to the Pay-Per-View phone port on your cable TV or satellite receiver.
- C. To connect a telephone - Connect one end of another phone cable to the other Power Console phone port labeled "OUT". Connect the other end of this cable to the telephone you want to use.

**Note:** We have included labels for the "Phone IN" and "Phone OUT" lines, if needed, for better organisation.

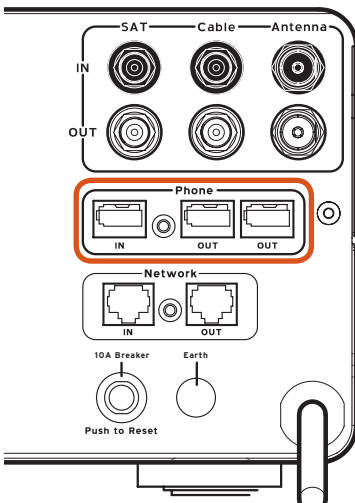

# Hookup and Installation

## Step 9

### Connect your Cable TV/Satellite Coaxial Lines

Your PureAV Power Console comes with two pairs of F-type coaxial-cable connections, and one pair of aerial-cable connections to protect your system from dangerous electrical disturbances that can travel down your cable/satellite/aerial-signal lines. You will need additional coaxial cables to connect the Power Console to your home cinema components.

- A. Satellite (DSS) TV** - Connect the incoming satellite television F-type coaxial-cable line to the connector labeled "SAT IN". Connect one end of a second coaxial cable to the connector labeled "SAT OUT". Connect the other end of this cable to your satellite TV tuner.
- B. Cable TV** - Connect the incoming cable television F-type coaxial-cable line to the connector labeled "Cable IN". Connect one end of a second coaxial cable to the connector labeled "Cable OUT". Connect the other end of this cable to your cable TV set-top box.
- C. Antenna** - Connect the incoming TV or radio antenna cable line to the connector labeled "Antenna IN". Connect one end of a second aerial cable to the connector labeled "Antenna OUT". Connect the other end of this cable to your TV or radio equipment.

**Note:** We have included labels for the "Coax IN" and "Coax OUT" lines, if needed, for better organisation.

**IMPORTANT WARNING:** To sufficiently safeguard all of your equipment from damage resulting from a power surge, all of your incoming coaxial-cable lines should be properly earthed. Contact a licensed electrician to verify that all of your cable lines are properly earthed to a cold water pipe or earth rod.

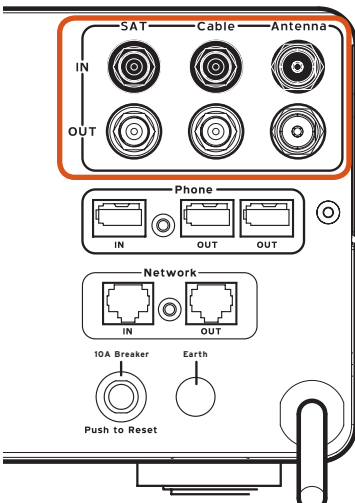



# Hookup and Installation

## Step 10

### Connect your Broadband Ethernet Line

Your PureAV Power Console comes equipped with broadband Ethernet-line protection. These are standard RJ45 Ethernet ports and they are labeled "Network".

- A. Connect one end of an RJ45 network patch cable to a network port (either directly to a router or wired network wall port). Connect the other end of the network patch cable to the network port labeled "IN".
- B. Connect one end of the broadband Ethernet cable (included) to the network port labeled "OUT". Connect the other end of this cable to the networked device (digital media receiver, gaming console, etc.)

**Note:** We have included labels for the "Network IN" and "Network OUT" lines, if needed, for better organisation.

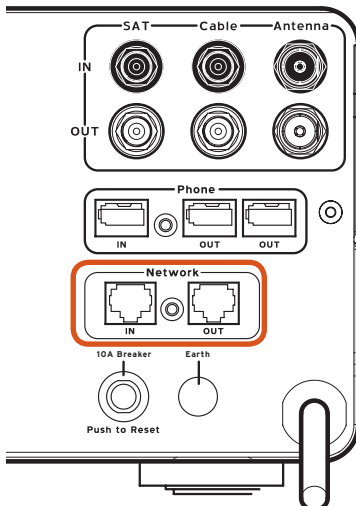

# Operation

## Central LCD Control Panel

The PureAV Power Console PF40 is equipped with an advanced LCD Control Panel. Most functions of the Power Console can be monitored from this display.

- A. PureFilter Indicator** - shows that the multiphase PureFilter Circuitry is functioning properly.
- B. Volt Meter** - displays the input voltage (the amount of voltage coming from the AC wall socket to the Power Console).
- C. Current Meter** - displays the output current (the amount of current output [in Amps] from the Power Console's socket banks).
- D. Wiring** - indicates whether the AC socket to which the Power Console is connected is wired properly, or cross-wired.
  - ✔ - Wiring OK.
  - ✘ - Live and neutral wires are reversed. See page 21 in the "Troubleshooting" section for more information.
- E. Earthed** - indicates if the Power Console is connected to a properly earthed AC socket.
  - ✔ - Earth OK. The AC wall socket is properly earthed.
  - ✘ - Earth Fault. This indicates that the AC wall socket is NOT properly earthed. See page 21 in the "Troubleshooting" section for more information.
- F. Switched Indicator** - shows whether the "Switched" sockets are switched ON or OFF.
- G. Timed Delay Indicator** - shows that the delayed sockets are switched ON after a delay.
- H. Remote Indicator** - shows whether the remote function is ON or OFF (controlled with the "Remote" button).
- I. Remote Button** - switches the Power Console to "Remote ON" status when pressed. When in "Remote ON" status, the Power Console sockets programmed as switched are turned ON/OFF via external remote signal (see page 8).
- J. Dimmer Button** - adjusts the brightness of the LCD Control Panel; press it repeatedly to change the brightness level.

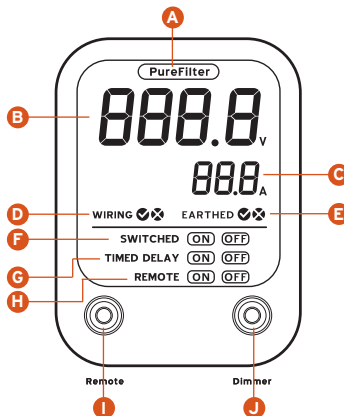

# Operation

## Auxiliary Power Socket

The Power Console is equipped with a front auxiliary power socket. This socket contains a digital noise filter and is a convenient place to connect digital video cameras, digital still cameras, MP3 players, game consoles, or any other portable device in need of AC power. Simply remove the small door covering the socket by sliding it to the right (Fig. 4) and plug in your device.

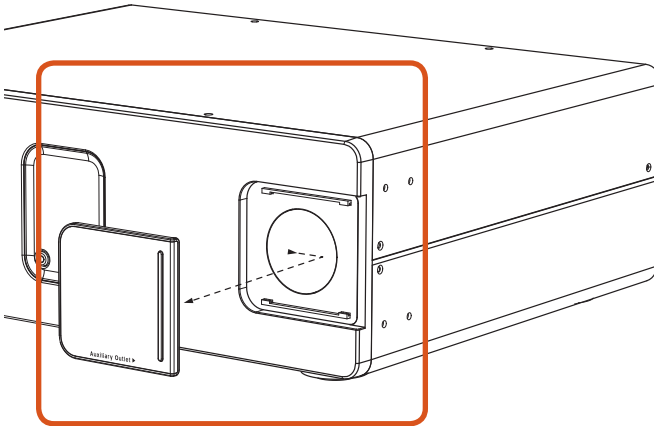

Fig. 4

# Technical Specifications

Specification	PF40
Electrical Rating	240V~10A/2400W
Product Weight (kg.)	6.8kg.
Product Dimensions (mm)	435 x 329 x 153mm (LxWxH)
Number of Sockets	10 Sockets
Cable Length	3M - SD1000
Joule Rating	7700J
Maximum Spike Current	264,000A
Response Time	<1 nanosecond
Coaxial Protection	3-in; 3-out
Telephone Protection	1-in; 2-out
Ethernet Protection	1-in; 1-out
Overload Protection	Yes
Power Safety Shutdown	$\leq 196\text{Vac} \pm 6\text{Vac} / \geq 264\text{Vac} \pm 6\text{Vac}$

# Troubleshooting

## **Power Console is not providing power.**

- Check to ensure that the Power Console is plugged into a properly earthed AC wall socket. Some sockets require a wall switch to be turned on in order to deliver power to the socket.
- Too many devices may be plugged into the Power Console, which are overloading the unit and tripping the overload circuit breaker. The Power Console is not designed to handle current loads larger than 10 Amps or 2400 watts. Try unplugging some devices and resetting the circuit breaker located on the end of the Power Console.

To reset the circuit breaker: Wait at least 10 minutes after the circuit breaker was tripped before attempting to reset the breaker. Press the button located next to the power cable on the back of the unit to reset. Power should be restored to the sockets on the Power Console.

- Your components may be plugged into a “Switched” socket and the socket is not switched on. Check to ensure that the “Switched ON” indicator on the Control Panel is illuminated. If the light is not illuminated, press the “Switched” button on the front of the Power Console unit until the “Switched ON” indicator is illuminated. You should now have power to all of the switched sockets.
- Your components may not be turned on. Power may be flowing from the Power Console, but if the power switch on your component is not turned on, your component cannot receive power. Turn on your component's power switch.
- The surge protection components may be expired. The Power Console is designed to stop delivering power to all sockets when the surge-protection circuitry is not functioning properly or is expired. Call Belkin Customer Service for assistance.
- The Power Console may be defective. Call Belkin Customer Service for assistance.

# Troubleshooting

**“Earth Fault” indicator is lit.**

**EARTHED** ⚡

- Check to make sure that the Power Console is plugged into an earthed AC wall socket. Do not use any plug adapters.
- If the “Earth Fault” indicator is still lit, you have an earth-wiring problem. Connecting the Power Console to an improperly earthed socket is not safe and will void all Belkin warranties. Unplug the Power Console and consult an electrician to properly earth the socket. If the socket is properly earthed and the “Earth Fault” indicator is still lit, the Power Console may be malfunctioning. Please call Belkin Customer Service for assistance.

**“Cross-Wired” indicator is lit.**

**WIRING** ⚡

- Check to make sure that the Power Console is plugged into an earthed AC wall socket. Do not use any plug adapters.
- This indicates that the live and neutral (L-N) wires are reversed. Unplug the Power Console and consult an electrician.

**For all other technical questions or troubleshooting issues, please contact Belkin Customer Service on 00 800 22355460.**

# Glossary of Power Terms

**Alternating Current (AC):** The current that is commonly flowing through the electrical sockets in your home. It is an electrical current in the form of a sine wave that oscillates up and down continuously.

**Amp:** An abbreviation for Ampere. This is a unit of electrical current.

**Direct Current (DC):** An electrical current flowing in one direction only. DC current does not have a wave form.

**Electromagnetic Interference (EMI):** Electrical interference generated by appliances and many other electrical components that cause degradation of sound and picture quality in audio and video equipment.

**Earth:** A conducting object, such as a wire, that is connected to a position of zero-voltage potential. Common connecting points are earth rods or cold-water pipes that are connected to the Earth.

**Joule Rating:** A measure of electrical energy. The higher the joule rating, the more electrical surges a device can absorb before failing.

**Maximum Spike Current:** The maximum current (in Amps) that can be absorbed before failing. The higher the maximum spike current, the more current a device can absorb without failing.

**Radio Frequency Interference (RFI):** Electromagnetic radiation, which is emitted by electrical circuits carrying rapidly changing signals as a by-product of their normal operation, and that causes interference or noise to be induced in other circuits.

**Spike:** A very fast transient variation in voltage or current. Many small transients, over time, cause components to wear and fail.

**Surge:** An increase in voltage or current significantly above the designated level in a flow of electricity.

# Belkin Connected Equipment Warranty

Belkin Limited warrants to the original consumer or other end-user of any PureAV Power Console for the life of the product, that the PureAV Power Console shall be free of defects in design, assembly, material or workmanship and will repair or replace, at its option, any defective PureAV Power Console free of charge.

Belkin Limited will repair or replace, at its option, any equipment ("connected equipment") that is damaged by a transient voltage surge/spike or lightning strike (an "Occurrence"), while properly connected through a PureAV Power Console to a properly wired power line with protective earth (the "Belkin Connected Equipment Warranty"). (For models AP2050Uk3M, AP2100Uk3M, AP4100Uk3M, the telephone line and the coaxial cable must be properly connected and installed).

This Belkin Connected Equipment Warranty is subject to the limitations and exclusions set forth herein. The warranties provided herein do not affect the consumer's statutory rights under applicable national laws in force, nor the consumer's rights against the retailer arising from its sales/purchase contract.

Belkin will spend, to repair or replace the damaged connected equipment, at its option, an amount equal to the fair market value of the damaged equipment or the original purchase price of the equipment, whichever is the less, up to a maximum set forth below:

- For model AP2050Uk3M (PF30), up to a maximum of £150,000
- For model AP2100Uk3M (PF40), up to a maximum of £200,000
- For model AP4100Uk3M (PF50), up to a maximum of £300,000

The fair market value of the equipment shall be the current retail market value of the same or similar model or specification as agreed by Belkin at the time it accepts or approves any claim.

Belkin reserves the right to review the damaged PureAV Power Console, the damaged equipment, and the site where the damage occurred. All costs of shipping the PureAV Power Console and the damaged equipment to Belkin for inspection shall be borne initially by the purchaser. Belkin reserves the right to negotiate the cost of repairs. If Belkin determines, in its sole discretion, that it is impractical to ship the damaged equipment to Belkin, Belkin may designate, in its sole discretion, an equipment repair facility to inspect and estimate the cost to repair such equipment. The cost, if any, of shipping the equipment to such repair facility and of such estimate shall be borne initially by the purchaser. Damaged equipment must remain available for inspection until the claim is finalised. Whenever claims are settled, Belkin Limited reserves the right to be subrogated under any existing insurance policies the claimant may have.



# Belkin Connected Equipment Warranty

All warranties provided herein are null and void if the PureAV Power Console has been improperly installed, altered in any way, tampered with, or if the connected equipment was not used under normal operating conditions or in accordance with any labels or instructions. All PureAV Power Consoles must be plugged directly into the power source and must not be “daisy-chained” together in serial fashion with other power strips, UPSes, other surge protectors or extension cables. Any such installation voids the warranties provided herein. The Belkin Connected Equipment Warranty does not protect against acts of God (other than lightning) such as flood or earthquake or against war, vandalism, theft, normal-use wear and tear, erosion, depletion, obsolescence, abuse, damage due to low voltage disturbances (i.e. brownouts or sags), non-authorized program, or system equipment modification or alteration.

This warranty contains the sole warranty of Belkin, and there are no other warranties, expressed or implied, including, except as to consumers, and the implied warranty of merchantability or fitness for a particular purpose. In no event shall Belkin be liable for consequential or indirect losses, including lost business, loss of profits, loss of service, loss of software, loss of information, damage to any computer media other than hardware or damage to or loss of any property arising out of the sale or use of any PureAV Power Console. Nothing herein shall serve to exclude or limit the liability of Belkin for the death or personal injury of the consumer resulting from the negligence of Belkin or for fraudulent misrepresentation.

This warranty is valid only for the original consumer or other end-user of the product and does not confer any rights on any other persons. The original consumer or other end-user must retain the original receipt or both the warranty to repair or replace the PureAV Power Console and the Belkin Connected Equipment Warranty are void. All damage claims arising under the Belkin Connected Equipment Warranty must be made within 15 days from the date of the Occurrence and must be accompanied by a receipt for the damaged equipment or the Belkin Connected Equipment Warranty is void.

This Warranty only applies to products used in their country of original intent.

# Belkin Connected Equipment Warranty

To file a claim against the Belkin Connected Equipment Warranty, you must take the following steps:

1. You must have an original receipt with date of purchase.
2. Contact a Belkin Limited Customer Service Representative at **00 800 22355460** within 15 days of the Occurrence.

Be prepared to provide the following information:

- a. The part number of the PureAV Power Console.
  - b. The equipment that was connected to the PureAV Power Console at the time of the Occurrence.
  - c. The equipment that was damaged during the Occurrence and the extent of the damage.
  - d. The date of the Occurrence.
  - e. Where you purchased the PureAV Power Console.
  - f. When you purchased the PureAV Power Console.
3. Your Belkin Customer Service Representative will then instruct you on how to forward your equipment, receipt, PureAV Power Console in use during the Occurrence and how to proceed with your claim.

Belkin Ltd  
Express Business Park, Shipton Way  
Rushden, NN10 6GL, United Kingdom  
+44 (0) 1933 35 2000  
+44 (0) 1933 31 2000 fax

Email: [eurosupport@belkin.com](mailto:eurosupport@belkin.com)  
[www.belkin.com](http://www.belkin.com)

# Notes

# BELKIN®

[www.pureav.com](http://www.pureav.com)

Belkin Ltd.  
Express Business Park  
Shipton Way, Rushden  
NN10 6GL, United Kingdom  
+44 (0) 1933 35 2000  
+44 (0) 1933 31 2000 fax

Belkin B.V.  
Boeing Avenue 333  
1119 PH Schiphol-Rijk,  
The Netherlands  
+31 (0) 20 654 7300  
+31 (0) 20 654 7349 fax

Belkin GmbH  
Hanebergstrasse 2  
80637 Munich  
Germany  
+49 (0) 89 143405 0  
+49 (0) 89 143405 100 fax

Belkin SAS  
130 rue de Sully  
92100 Boulogne-Billancourt  
France  
+33 (0) 1 41 03 14 40  
+33 (0) 1 41 31 01 72 fax

© 2005 Belkin Corporation. All rights reserved. All trade names are registered trademarks of respective manufacturers listed.

P74978uk